

# RIGOL

## User's Guide

# RPL2316

## LOGIC PROBE

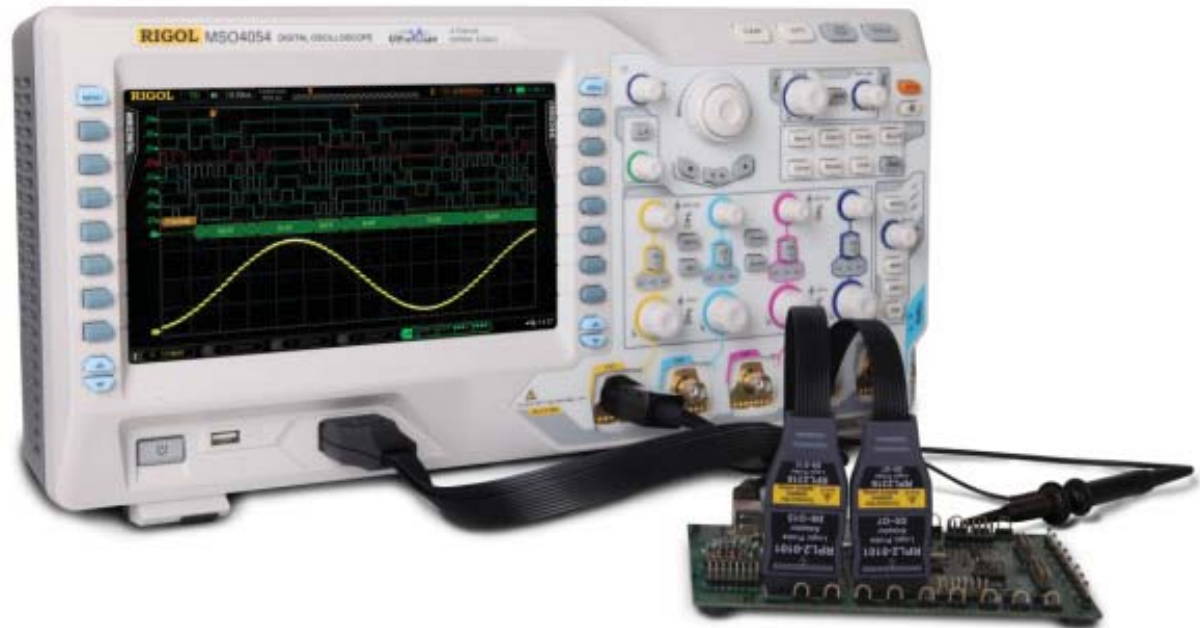

Distribution in the UK & Ireland













**Lambda Photometrics Limited**  
Lambda House Batford Mill  
Harpenden Herts AL5 5BZ  
United Kingdom

**Characterisation,  
Measurement &  
Analysis**

**E:** [info@lambdaphoto.co.uk](mailto:info@lambdaphoto.co.uk)  
**W:** [www.lambdaphoto.co.uk](http://www.lambdaphoto.co.uk)  
**T:** +44 (0)1582 764334  
**F:** +44 (0)1582 712084

## General Safety Summary

-  Connect and disconnect the probe properly.
-  Connect the adaptor before using.
-  Observe all terminals ratings.
-  Do not touch exposed connections and components after power on.
-  Do not operate with suspected failures.
-  Do not operate without covers.
-  Do not operate in an explosive atmosphere.
-  Do not operate in wet conditions.
-  Keep product surface clean and dry.
-  Pay attention to handling safety.

## Product Overview

Being a high performance logic probe, RPL2316 connects the digital buses and signals under test to the MSO4000 series digital oscilloscope. RPL2316 separates 16 digital channels into two branch headers, called channel group. Each header includes 8 signal channels (D0-D7 and D8-D15) plus 12 ground channels. All the channels are marked with different colors and numbers (or letters) on the probe adaptor label to identify different channels. RPL2316 provides 8 signal leads and 12 ground leads for each header to realize flexible connection of signals and reference ground and provide better signal integrity. Note: in any case, make sure that the connection between probe adaptor and the channel group is reliable.



## The Using Method of the Logic Probe

- 1. Connect RPL2316 to the oscilloscope:** push the buttons on both sides of the logic probe single head and connect it (with "**RIGOL**" facing upward and the label facing downward) to the digital channel input terminal [**LOGIC D0-D15**] at the front panel of the MSO4000 series digital oscilloscope in the arrow direction as shown in the figure below.

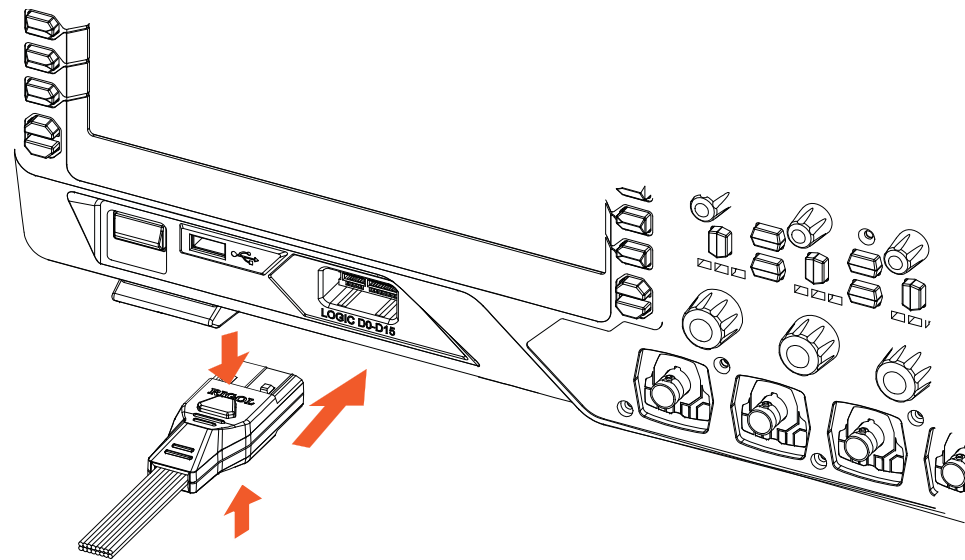

- 2. Connect the signals under test to RPL2316:** users can connect any number ( $\leq 16$ ) of the signals under test to RPL2316 in according to the test need. Make sure that the amplitude of the input signal should not exceed the maximum working voltage range while connecting. RPL2316 provides three connection methods with the signals under test for different applications.
- ◆ Method one: you can connect RPL2316 to the two rows of pins on the device under test directly. At this point, the probe adaptor must be connected as shown in figure 1.
  - ◆ Method two: you can connect the signals under test through leads separately. At this point, the probe adaptor must be connected as shown in figure 2. You can easily identify the corresponding channel of each signal by the color rings on the leads and the color information on the adaptor.

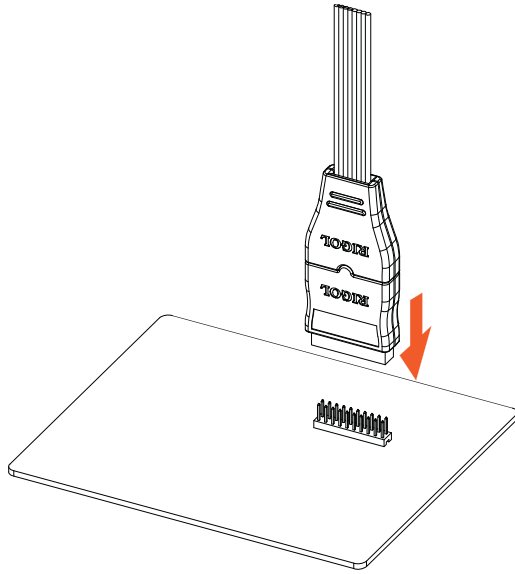

Figure 1

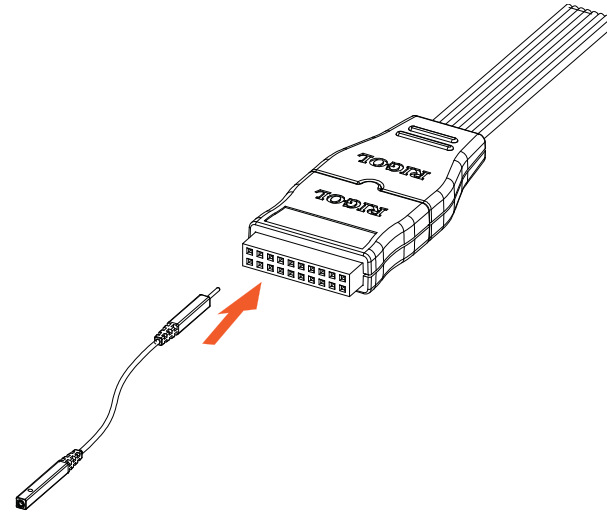

Figure 2

- ◆ Method three: on the basis of method two, you can connect a grabber to each lead and connect it to the device under test as shown in figure 3.

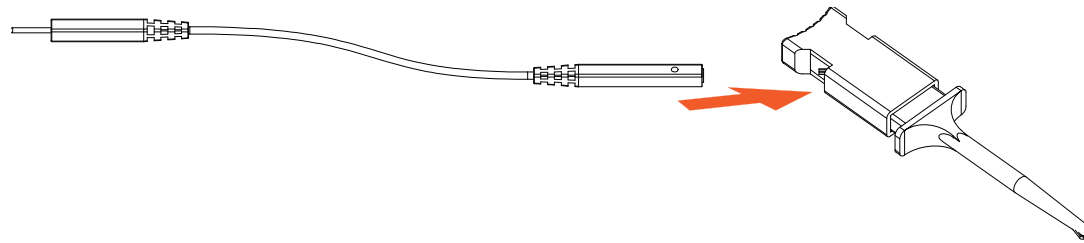

Figure 3

- 3. Set the probe:** press **LA** at the front panel of the oscilloscope to enter the probe setting menu. Users can view and set the following parameters under this menu: threshold level (the threshold levels of D0-D7 and D8-D15 can be adjusted independently), waveform size (applicable to all the channels; wherein, item L is only available when the number of active channels is no more than 8), channel label and digital bus (provide 2 independent digital buses to set various parameters respectively, such as the clock, bit width, display format and noise rejection; for more flexible functions, use common bus).
- 4. Function Check:** after finishing the above operations, the signal under test will be displayed on the corresponding channel. If no active signal is displayed, please adjust the oscilloscope to select proper general settings (such as the trigger mode and timebase). If active signal is still not displayed, please check the electric connection and parameter settings again or please try to use other probe (such as analog probe) to check the signal state of the test point.

## Probe Specifications

Input Channels	16
Threshold Range	$\pm 20V$
Threshold Accuracy	$\pm 100mV+3\%$ of threshold setting
Max Voltage Swing	$\pm 40V$
Min Voltage Swing	500mV
Min Detectable Pulse Width	5ns
Input Impedance	101k $\Omega$
Probe Load	About 8pF
Cable Length	About 100cm
Lead Length	About 15cm
Operation Environment	0~50°C, 0~80%RH
Storage Environment	-20°C~60°C, 0~90%RH



## Accessories

<b>Item</b>	<b>Description</b>	<b>Quantity</b>
1	Main Cable	1
2	Logic Probe Adaptor	2
3	Lead	20 (2×10)
4	Grabber	20
5	Chinese and English User's Guide	1
6	RPL2316 Soft Carrying Bag	1

# Accessories Sketch Map

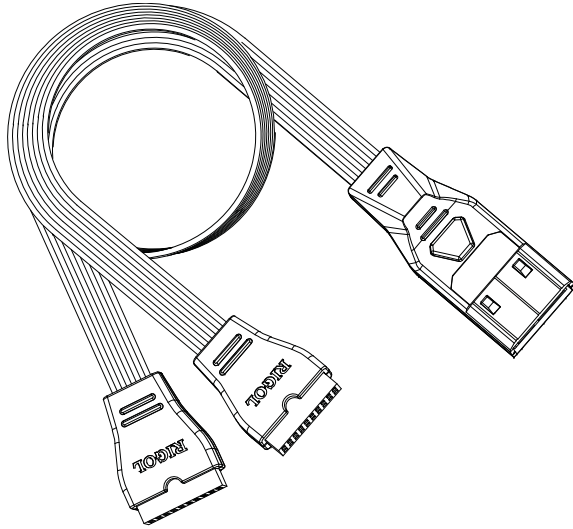

Main Cable

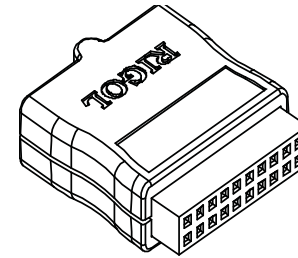

Logic Probe Adaptor

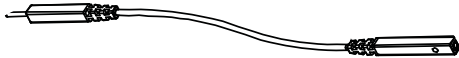

Lead

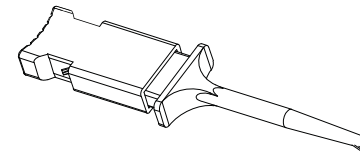

Grabber

Distribution in the UK & Ireland



**Lambda Photometrics Limited**

Lambda House Batford Mill

Harpenden Herts AL5 5BZ

United Kingdom

**Characterisation,  
Measurement &  
Analysis**

**E: [info@lambdaphoto.co.uk](mailto:info@lambdaphoto.co.uk)**

**W: [www.lambdaphoto.co.uk](http://www.lambdaphoto.co.uk)**

**T: +44 (0)1582 764334**

**F: +44 (0)1582 712084**

UGE20X03-1110

Aug. 2014

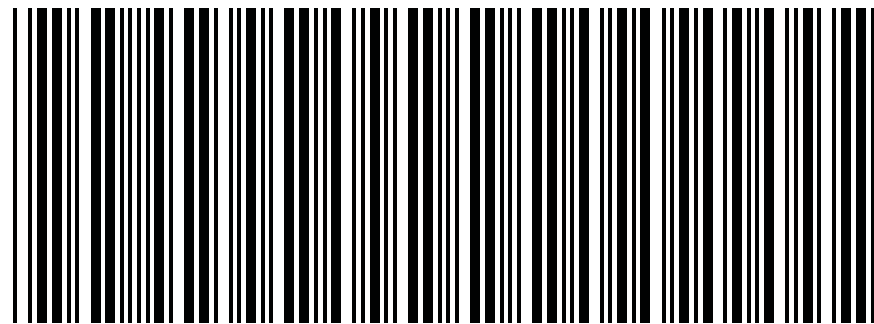

ZN1 020002292